

4

3

2

1

THIS DRAWING IS UNPUBLISHED. RELEASED FOR PUBLICATION
 © COPYRIGHT BY TYCO ELECTRONICS CORPORATION. ALL RIGHTS RESERVED.

LOC	DIST	REVISIONS			
P	LTR	DESCRIPTION	DATE	DWN	APVD
G	86	C	REVISED PER ECR-08-018477	07AUG08	HMR TM

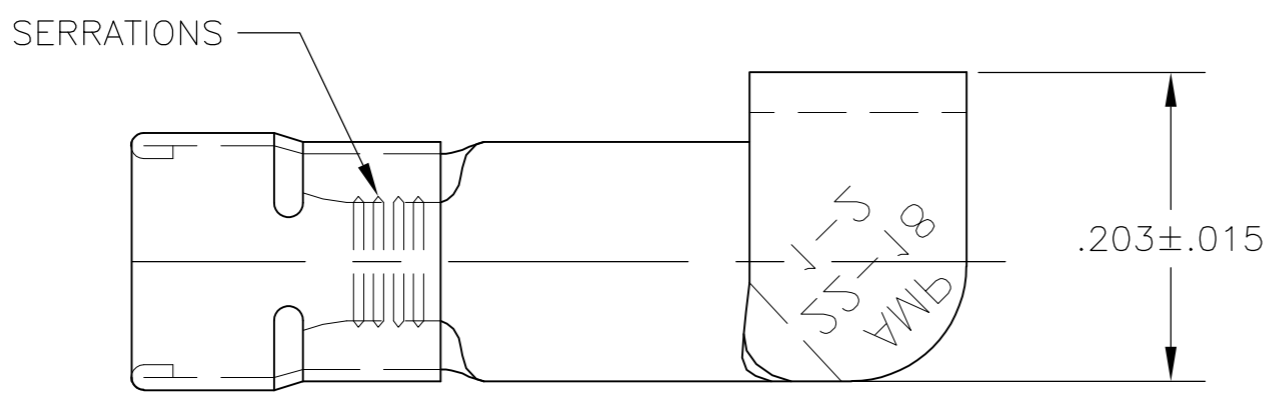

- 1 FOR .105 TO .140 WIRE INSULATION DIA
- 2 MARKING 22-18 FOR MILITARY COMMERCIAL RANGE 22-16.
- △3 BODY & SLEEVE: COPPER PER ASTM-B152
- △4 TIN PLATE .000100 MIN THK PER ASTM-B545

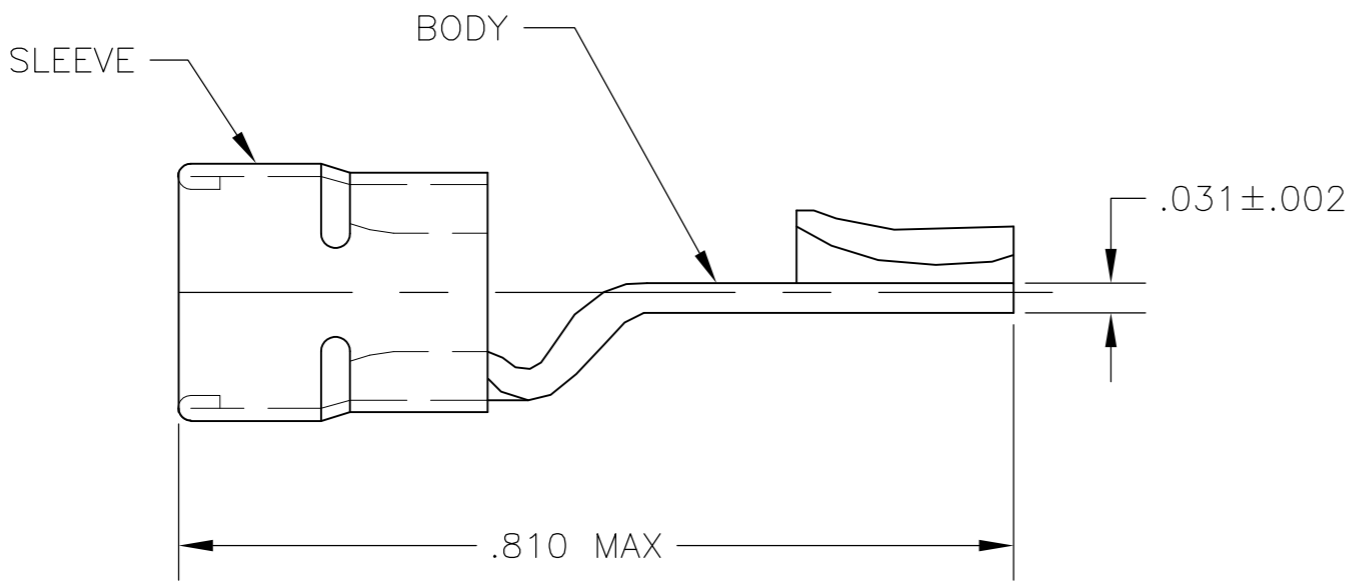

5000	31777 ON TAPE	2-31777-2
1000	LOOSE PIECE	31777
QTY	PACKAGE TYPE	PART NO

THIS DRAWING IS A CONTROLLED DOCUMENT.		DWN RAGAHVENDRA 07AUG08	Tyco Electronics Corporation Harrisburg, PA 17105-3608													
DIMENSIONS: INCHES		CHK T MICHELUTTI 07AUG08	NAME													
TOLERANCES UNLESS OTHERWISE SPECIFIED:		APVD T MICHELUTTI 07AUG08	WIRE TERMINAL DIAMOND GRIP-KNIFE DISCONNECT WIRE SIZE: 22-16													
<table border="1"> <tr><td>0 PLC</td><td>± -</td></tr> <tr><td>1 PLC</td><td>± -</td></tr> <tr><td>2 PLC</td><td>± -</td></tr> <tr><td>3 PLC</td><td>± .008</td></tr> <tr><td>4 PLC</td><td>± -</td></tr> <tr><td>ANGLES</td><td>± 5'</td></tr> </table>		0 PLC	± -	1 PLC	± -	2 PLC	± -	3 PLC	± .008	4 PLC	± -	ANGLES	± 5'	PRODUCT SPEC -	SIZE A3	RESTRICTED TO -
0 PLC	± -															
1 PLC	± -															
2 PLC	± -															
3 PLC	± .008															
4 PLC	± -															
ANGLES	± 5'															
MATERIAL △3		APPLICATION SPEC -	CAGE CODE 00779	REV C												
FINISH △4		WEIGHT -	DRAWING NO 31777													
CUSTOMER DRAWING			SCALE 5:1	SHEET 1 OF 1												